

Activity 1 – sheet 1 of 2

Programme Questions

Current and Voltage

1. What happens to the brightness of light bulbs as more are added:

- a) in series?
 - b) in parallel?
-

2. What happens to the total current flowing from the power supply as more bulbs are added:

- a) in series?
 - b) in parallel?
-

3. What is the relationship between the supply voltage and the voltage across each component:

- a) in a series circuit?
 - b) in a parallel circuit?
-

Ohm's Law

1. If a graph of the voltage across a wire is plotted against the current flowing through it:

- a) What shape is the graph?
 - b) What does the gradient of the graph tell you about the wire?
 - c) What law does the graph show is true for a wire?
-

2. What shape is a graph of voltage against current for a light bulb?

Activity 1 – sheet 2 of 2

Programme Questions

Changing Resistance

1. If pieces of wire are the same length and thickness, but made of different metal, will their resistance be the same or different?

2. The resistance of a piece of wire is measured. If a longer piece of the same wire is tested will it have:

- a) the same resistance?
 - b) lower resistance?
 - a) higher resistance?
-

3. Draw a diagram of a metal lattice showing the positive ions and the electrons flowing through the lattice when an electric current flows through the metal:

- a) for a wire
 - b) for a thicker wire, which has lower resistance
-

4. What happens to the resistance of a wire as it is cooled?

5. Explain your answer to question 4 by describing what happens to the lattice of positive ions and the sea of free electrons.

Activity 2 – sheet 1 of 1**Resistance of Wire**

An experiment was done to find the resistance of some wire. The wire was connected in a circuit. As the voltage was increased the current was measured. Here are the results for two different wires:

Wire A

Voltage (V)	Current (A)
2	0.3
4	0.6
6	0.9
8	1.2
10	1.5
12	1.8

Wire B

Voltage (V)	Current (A)
2	0.1
4	0.2
6	0.3
8	0.4
10	0.5
12	0.6

1. Use graph paper to plot a graph of voltage V (in volts) on the vertical axis against current I (in amps) on the horizontal axis. Plot the graph for wire A and wire B on the same axes.
2. Do the wires obey Ohm's Law? How can you tell?
3. Which wire has the highest resistance?

The resistance R can be calculated from the gradient of the graph $R = V/I$

4. Calculate the resistance of wire A and wire B.
(Remember to use the units of resistance for your answers.)

Here are some results for a component:

Voltage (V)	Current (A)
0	0
2	0.4
4	0.7
6	0.9
8	1.0
10	1.06
12	1.1

5. Plot the graph of voltage against current for this component.
6. Does this component obey Ohm's Law?
7. Can you suggest what the component might be?

Activity 3 – sheet 1 of 2

Ohm's Law

Using the equation $V = IR$ to solve these problems.

The resistance of a piece of wire depends on its length. (If you double the length of the wire you double the resistance.)

- Sam wants to know how much insulated wire there is on a spool.
- She does an experiment to find the resistance of a 1m length of wire.

1. a) If voltage $V = 4V$ and current $I = 0.8A$, what is the resistance of the 1m piece of wire?

- Next she connects the ends of the wire on the spool to the voltmeter and the ammeter as in the diagram.
- She measures the voltage and the current for the whole length of the wire on the spool.

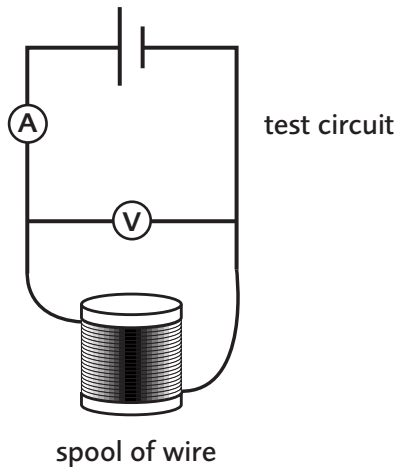

b) If voltage $V = 10V$ and current $I = 0.02 A$, what is the resistance of the whole length of the wire?

c) Now you have the resistance of 1m of wire, and the resistance of the whole length, use these numbers to work out how many metres of wire there are on the spool.

d) The wire was insulated with a plastic sleeve. Explain why the experiment wouldn't have worked with wire that wasn't insulated.

2. Use the equation $V = IR$ to work out the missing quantity in these circuits:

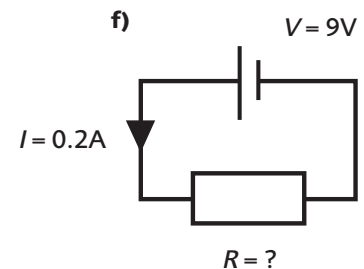
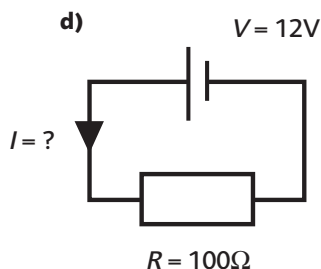
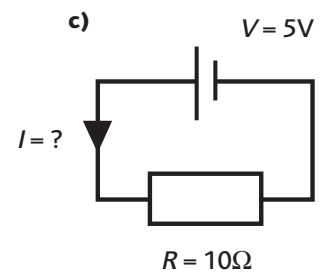
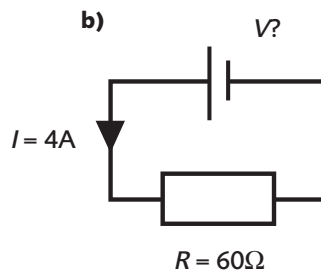
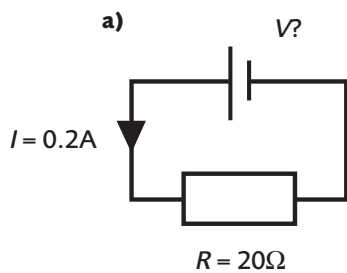

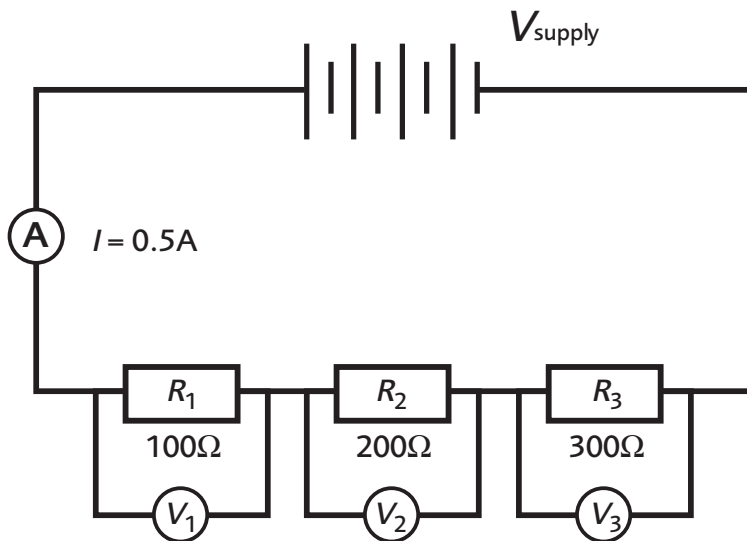
Activity 3 – sheet 2 of 2**Ohm's Law**

3. a) Look at the series circuit. Write down a relationship between the readings on the voltmeters.
b) Use $V = IR$ to work out the voltage across each resistor.
c) What is the supply voltage?